



Tube Technologies, Inc.
1555 Consumer Circle
Corona, CA 92880
Ph. (951) 371-4878
www.ttiexhaust.com

INSTALLATION INSTRUCTIONS for TTI Small Block Header Part No': **TTI340AW2**

TAKE TIME TO READ THE INSTALLATION PROCEDURES BEFORE STARTING

WARNING !!!

We strongly suggest that you use an old set of headers or a set of cast iron manifolds for first engine runs / cam break-ins to avoid coating damage. Excessive heat damage to the ceramic coating will **VOID** all warranties.

Header coating damage usually occurs during the first engine run when the exhaust temperatures exceed 1200°F. Excess exhaust temperatures are normally caused by excessively lean or excessively rich air/fuel mixtures and/or incorrect ignition timing.



Please take all under car safety precautions when installing headers, including eye protection. When raising vehicle, use an appropriate lifting device and place on jack stands as a safety measure. Caution! Bumper jacks are intended for emergency use only and should not be used to support vehicle.



First check your Engine Location





TTI's headers were designed to fit with the engines located to the factory specifications. If the engine is not located correctly in the chassis, the headers will not fit properly. Use the following dimensions to check your engine location before installing your headers. From the center of the crankshaft to the top of the K-frame the correct distance is 5-1/4". The engine is also offset toward the passenger-side. Measure from the center of the crankshaft to each frame rail. The difference should be 2-1/2". If necessary place shims between the insulator assembly and the K-frame mounting pad to achieve the proper dimensions. With the engine mounted in the correct location the headers will fit properly.

1. Disconnect the negative cable from the battery terminal.
2. Raise the front of the vehicle with an appropriate lifting device and place on jack stands.
3. Disconnect the plug wires and remove all of the spark plugs. Remove the cast iron manifolds and the stock exhaust pipes. If you are installing the complete TTI Exhaust System, then remove and discard your entire stock exhaust system, including hangers.
4. Remove the oil filter and the starter. Passenger-side, remove and discard the brace between the engine and the transmission. Drivers-side, remove the lower mounting stud for the starter and replace it with a bolt.
5. Now is a good time to check the condition of your engine mounts. If they are worn or deteriorated, replace them now. When the engine is mounted correctly the headers will fit correctly.
6. Drivers-side Header: Use a pickle-fork to loosen the ball joint on the drag link at the pitman arm and the left tie rod. Remove the bolt from the idler arm swing this assembly aside. Remove the drivers-side engine mount bolt and raise the engine approximately 1 1/2". Use a block of wood between the oil pan and the floor jack.
 - On models with Automatic Transmission and Floor Shift, re-position the adjustable swivel and the lower rod attached to the torque shaft lever. Move them to the upper side of the torque shaft lever to clear the header collector. See the modified Torque Shaft Lever illustration on our sheet #3703.
 - Check the cylinder head sealing surface of the exhaust ports to insure that they are clean. Place the supplied header gasket into position on the studs. Remove the #7 tube from the header. Insert the header into position from under the car. Before bolting to the cylinder head, slip the rear cylinder #7 tube in between the frame and the torsion bar into the slip-connector (lightly grease the inside of slip) of the header. Lower the engine and place the header into position on the cylinder head. Use the original studs and nuts or the provided headers bolts to secure the header to the cylinder head. Tighten the center bolts first then the end ports. Torque the bolts to 25 lbs. evenly to insure a proper seal.

- Reinstall the steering linkage assembly by reversing the disassembly procedure. Be extremely careful to re-install all nuts, bolts and pins that were removed. Install motor mount bolt.
 - Install the starter and connect the wiring. Adjust the wiring to insure that there is absolutely no contact with the header. Due to variations in the routing of brake lines, it may be necessary to re-position a brake line to achieve adequate clearance from a header tube. A minimum clearance of 1/2" from a header tube is required.
7. **Passenger-side Header:** Check the sealing surface of the exhaust ports to insure they are clean. Place the supplied header gasket into position on the studs. Turn the steering wheel to the full left position. Insert the header into position from under the car. Use the original studs and nuts or the provided header bolts to secure the header to the cylinder head. Tighten the center bolts first then the end ports. Torque the bolts to 25 lbs. evenly to insure a proper seal. Install the oil filter.
 8. Attach the adapter / reducers to the header collectors with the nuts, bolts and gaskets provided. The adapter / reducers are 9" long and may need to be shortened for your application.
 9. Re-connect the negative battery cable.
 10. Now that your headers are installed, wipe down the tubes with hot soapy water or an environmentally safe Orange Cleaner Degreaser and a soft cloth to remove any grease or skin oils (finger prints) from the header tube surface. Never use abrasive cleaners.
 - It is normal for Chrome plated headers to discolor almost immediately after firing-up engine.
 - To insure years of service from your ceramic-coated headers it is suggested to follow our Header Maintenance & Care procedures.
 11. Start the engine and check for leaks.

 **Re-torque all of the header bolts after approximately 50 miles of driving**

To complete the rest of your exhaust system installation, we highly recommend the use of our TTI Performance Exhaust Systems. The 2-1/2" or 3" O.D. kits will bolt directly to the TTI Headers. Our exhaust systems come complete with all hardware and all new hanger assemblies. They are manufactured with aluminized tubing and are mandrel bent by the latest technology CNC tube benders insuring precision fit on every installation.

		<p>(2) Header Gaskets Made from high density non-asbestos fiber metal core composites. Its robust construction provides excellent sealing performance.</p>
		<p>(12) Zinc Plated Header Bolts 5/16-18x1</p>
<p>1-5/8" Primary Tubes 1-3/4" Secondary Tubes 3" Collectors</p> <p>A-body Header only: #7 Slip-Tube designed to be removed from the header for fitment around the torsion bar.</p>		<p>Header Reducer / Adapter kit: (2) 9" long aluminized tubes with welded 3-bolt 3/8" thick flanges. (2) 3-bolt 1/16" thick gaskets. (6) 3/8-16x1.25 zinc plated HH bolts grade 2, nuts & washers. Footnote: <u>16</u></p>



Tube Technologies, Inc.
 1555 Consumer Circle
 Corona, CA 92880
 Ph. (951) 371-4878
 www.ttiexhaust.com

HEADER APPLICATION
 for TTi Small Block Header Part No':

TTI340AW2

1967-1976 A-bodies		Footnotes
Front End	Stock	
Engine Sizes	273 / 318 / 340 / 360 A-engines 402 Magnum Crate engines	<u>37</u>
Cylinder Heads	W2 Econo Head - Casting no. 3870810 W2 Chrysler Classic Head - Part no. P4532693 Mopar Aluminum Magnum Head - Part no. P4876624	<u>14</u> , <u>26</u>
Auto Trans	Yes	<u>23</u>
Standard Trans	Yes	<u>53</u>
Floor Shift	Yes	<u>23</u>
Column Shift	Yes	<u>6</u>
Push Button	Yes	
Power Steering	Yes	
Manual Steering	Yes	
Air Conditioning	Yes	
Starters	OEM or Listed starters only	<u>10</u> , <u>18</u>
Steering Linkage	OEM only	<u>12</u> , <u>33</u>
Clutch Linkage	OEM only	<u>22</u>
Oil Filters	Screw-on short style or a 90° Remote Adapter	
Oil Pans	OEM or Milodon	<u>11</u>

Footnotes

<u>10</u>	Starters: Chrysler Lightweight Mini Starters - part #'s: R53005984, 56027702AC Mopar Performance Lightweight Mini Starters - part #'s: P5249644AB, P5007860, P4286522 PowerMaster Adjustable Starter - part # 9523
<u>11</u>	Oil Pans required: 7-3/4" - 8-3/4" sump depth / Milodon part #'s: 30935, 30936, 30940, 30941
<u>12</u>	Pitman Arm and Idler Arm: Headers will not clear the "Fast-Ratio" pitman and idler arms, which are 3/4" longer than stock arms. (Stock idler arm measures 5-1/4" from center to center)
<u>14</u>	If your cylinder head is not listed, TTI will not guarantee fit due to clearance issues, ie; Deck height, port locations or bolt pattern.
<u>16</u>	Header Reducers / Adapters: Apply light grease or oil to the inside of the slips of the H-pipe and install the reducer/adaptor into the slips. Bolt directly to TTI header collectors. In some cases the reducer/adaptor may require shortening. Clamp in place after fitting & aligning.
<u>18</u>	Lightweight Mini Starters & the Powermaster Starter can easily be changed without removing the header.
<u>22</u>	Some Z-bars may require modification to clear header.
<u>23</u>	Torque Shaft Lever: Applications with an Auto Transmission & Floor Shifter will require the adjustable swivel and the lower rod attached to the torque shaft lever to be re-positioned to clear the header collector. Do-it-yourself modification Instruction sheet: #3703
<u>33</u>	Unisteer Rack & Pinion: Headers will <u>not</u> clear.
<u>37</u>	Headers fit with Schumacher engine mounts or equivalent.
<u>53</u>	Transmission: Headers <u>will</u> fit with the Tremec TKO-500 / TKO-600 5-speed by Keisler.

Automatic Transmission with Floor Shifter will require repositioning of the adjustable swivel and lower rod attached to the torque shaft lever. Move them to the upper side of the torque shaft lever to clear the header collector. Some models will require additional modification for clearance of the shifting lever. (See diagram)

The support bracket is cut through and overlapped approximately 1/4" and re-welded, making it shorter and moving the shift lever away from the collector.

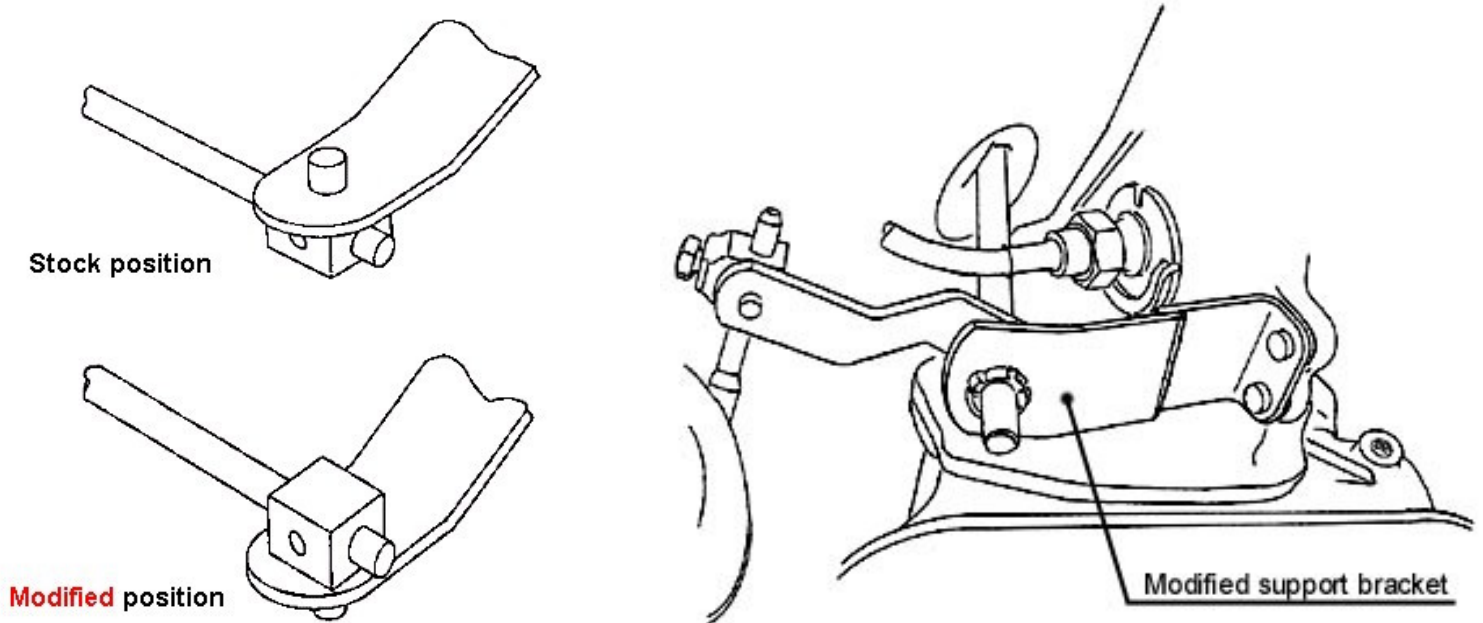



Tube Technologies, Inc.
1555 Consumer Circle
Corona, CA 92880
Ph. (951) 371-4878
www.ttiexhaust.com

ALUMINIZED EXHAUST SYSTEMS

Helpful hint to extend the life of your TTI Performance Exhaust System...

Exhaust system corrosion will occur if moisture (condensation) is not cleared out of the exhaust system. Make sure that the vehicle is driven at least 20 to 30 minutes when ever the car is started to completely dry out all liquid / acid that is created by the combustion process in the engine. Failure to do so will cause pre-mature rotting of the exhaust from the inside out.

HEADERS

TTI strives to offer the highest quality header coatings available on the market today. However, high performance coatings do require care and maintenance. The following tips are suggested to insure years of service of your Nickel-Chrome / Ceramic-Coated / Polished Ceramic Coated & Stainless Steel Headers.

WARNING: First Engine Runs - Header coating damage usually occurs during the first engine run when the exhaust temperatures exceed 1200°F. Excess exhaust temperatures are normally caused by excessively lean or excessively rich air/fuel mixtures and/or incorrect ignition timing. For this reason we strongly suggest that you use an old set of headers or a set of cast iron manifolds for your first engine run / cam break-in. This will insure that you will not damage the coating or void the warranty of your new TTI ceramic-coated headers.

After Header Installation and Before Engine Run - Remove grease and/or skin oils from the header tube surface. Stains & fingerprints will show when header gets hot.

? Nickel Chrome Plated Headers: Wipe down tubes with rubbing alcohol and a soft cloth, dry thoroughly.

? Ceramic Coated / Polished Ceramic Coated Headers / Stainless: Wipe the tubes down with an environmentally safe Orange Cleaner Degreaser or mild soap, warm water and a soft cloth, dry thoroughly.

When storing your car for an extended period of time, some precautions must be taken. Park the car over a large sheet of plastic or tarp. This will protect your car and headers from moisture seeping up through the floor. Wipe down and dry the headers thoroughly. Then coat the headers with WD-40 or an equivalent where the tubes are welded to the header flanges and where the tubes come in close proximity to each other (especially where the four tubes enter into the collector). These areas are prone to rusting, as the coating is unable to get between the tubes in the unexposed areas of the header. If rust occurs, it will travel into and under the coating and create a stain. When you are ready to start the car after storage, wash the WD-40 off by following the cleaning procedures.

Cleaning: Road grime / Oil / Grease / Surface deposits (surface rust) from water or other liquids

- Use an environmentally safe Orange Cleaner Degreaser, warm water and a soft cloth. Two or Three cleanings may be required. Be sure to dry thoroughly.
- Use cleaning compounds like, Nevr-Dull, Mothers or Wax Shop and about 15-20 minutes of elbow grease.
- Stainless Steel: Nevr-Dull Wadding Polish

Polish to Revitalize Coating

- Nickel Chrome Plating: Bluing / discoloration is inevitable. You cannot remove it, although there are products that claim to do so like, Blue-Job Chrome Restorer.
- Ceramic Coated / Polished Ceramic Coated: Mothers PowerMetal or Nevr-Dull.

For More Aggressive Cleaning: Stains / Baked-on Oils or Fluids / Melted-on Microfiber Towels or Plastic Grocery Bags (Yes, this happens a lot)

- Try a Super-fine "0000" Steel wool pad or use an Ultra-fine Scotch-brite pad.
- If all else fails, spray paint! Use Krylon 1402 High Heat Spray Paint – Aluminum color. Once headers heat up, color will or should blend.

⚠ Unfortunately, you cannot bring back a "High Luster" Polish ("C5" coating option) appearance.



Tube Technologies Inc.
1555 Consumer Circle
Corona, CA 92880
(951) 371-4878
www.ttiexhaust.com

Sheet #0708WA

90-Day LIMITED WARRANTY **Mfg. by Tube Technologies, Inc.**

TTI warrants all products to the original purchaser to be sold free of defects in material and workmanship for 90-days from date of purchase. In the event of an alleged defect in material or workmanship contact TTI at (951) 371-4878. Please provide a proof of purchase reference at time of call for quicker look-up. Ex: Invoice #, Packing List # or Sales Order #.

TTI does not warrant products that have been damaged caused by abuse, neglect, accident, improper installation or use on other applications other than recommended by TTI Performance Exhaust and Headers. Under no circumstances will TTI replace, repair or refund any product that has been altered in any way, mutilated or shows evidence of the use of insulating wrap products. TTI will not warranty cost of removal or re-installation of a product or will not be responsible for any shipping charges incurred. TTI will not assume responsibility for mufflers meeting individual customer's preference or the specific sound ordinances in any city, county and/or state. TTI reserves the right to make changes in design, materials and specifications or to make product changes as deemed necessary without prior notice.

Return Policy - Returned merchandise is subject to a 10% restocking fee. TTI does not refund freight. Contact TTI at (951) 371-4878 or the Authorized TTI Distributor from whom the merchandise was purchased through to receive a "Return Merchandise Authorization Number" (RMA #). Proof of purchase required! (Invoice, Packing List or Sales Order #) Return the merchandise along with a copy of your proof of purchase to: TTI Returns Dept. • 1555 Consumer Circle • Corona, CA 92880. Enclose a written reason for the return with a contact phone number and clearly write the RMA # on the outside of the box. Merchandise must be received in resalable condition. Final issuance of credit / refund is subject to receipt and inspection of merchandise by Tube Tech. Inc.

WARNING: Parts damaged in transit due to insufficient packaging may incur repair charges by TTI.

For general packaging guidelines to help prepare your package for safe shipping, visit our website at: www.ttiexhaust.com, Warranty, and click on "Packaging Guidelines & Procedures".

2-Year LIMITED "CERAMIC COATING" WARRANTY **by Engineered Applications (EA)**

In the event of an alleged defect in the coating; peeling, chipping, flaking or rusting, complete a "Coating Warranty Return Form" and return it along with parts to: Engineered Applications.

Proof of Purchase required! (Invoice, Packing List or Sales Order #)

Final determination of warranty is subject to receipt and inspection of parts by EA. EA will not accept liability for products that have been damaged caused by abuse, neglect, accident, improper installation, shows evidence of insulating wrap products or show evidence of adverse conditions such as; High heat temperatures encountered during engine break-in.

NOTE: Engineered Applications sole responsibility is strictly to strip-off existing coating, recoat and return it back to you. EA will not warranty any labor related costs.